

Publikasi 5

by Iyan 5

Submission date: 23-Nov-2017 01:56PM (UTC+0700)

Submission ID: 884423314

File name: IJPSR15-06-08-003.pdf (185.44K)

Word count: 4216

Character count: 22552

COMPARTMENTAL MODELLING APPROACH OF FLOATING- MUCOADHESIVE NIFEDIPINE TABLET IN VITRO AND IN VIVO

Endang Diyah Ikasari^{1*)}, Achmad Fudholi²⁾, Sudibyo Martono²⁾, Marchaban²⁾

^{1*)} Yayasan Pharmasi College of Pharmacy, Semarang 50193, Indonesia
Jl. Letjen Sarwo Edhie Wibowo Km 1. Pucur ggading Semarang 50193, Indonesia
Email: eri_ung@yahoo.com

²⁾ Faculty of Pharmacy, Gadjah Mada University, Yogyakarta 55821, Indonesia

Abstract

Development of nifedipine into a floating-mucoadhesive system is important due to its low oral bioavailability. The optimal formula of nifedipine tablet has been found which consisted of 12.02% carbopol 934P, 5% gelatin, and 7.98% gas generator. This study was aimed to develop and evaluate compartmental modelling of nifedipine tablet into a floating-mucoadhesive system in vitro and in vivo. In vitro evaluation based on dissolution profiles using dissolution apparatus type II which was filled with simulation gastric fluid (SGF) pH 1.2 at time 0,30, 60, 90, 120, 150, 180, 210, 240, 270, 300, 330, and 360 min. In vivo evaluation based on concentration nifedipine in the plasma after oral administration using white male rats Wistar strain as a subject. Both samples were collected and analyzed using WinSAAM method. Three compartmental model was proposed for dissolution profiles and four compartmental model was proposed for in vivo, i.e. model with one lag compartment. The visual goodness of fit (GOF) confirmed the modelling approach for each evaluation. Lag compartment was formed from polymers (carbopol 934P and gelatin). This polymers play major role in controlling the drug release from tablet, thus achieving the desired bioavailability.

Keywords: nifedipine, floating mucoadhesive, in vivo, in vitro, controlled manner

INTRODUCTION

Nifedipine is a calcium channel blocker, which belongs to dihydropyridine derivatives. The recommended adult oral dosage of nifedipine is 10-40 mg given twice daily. The drug has a short biological half-life of approximately 2-3 hours, an absolute bioavailability of 45-75%, and it is absorbed only in the initial part of the small intestine. The formulation in sustained release dosage form, an especially gastro retentive system is desirable.

Gastroretentive systems can remain in the gastric region for several hours and hence significantly prolong the gastric residence time of drugs. Prolonged gastric retention improves bioavailability, reduces drug waste, and improves solubility for drugs that are less soluble in a high pH environment. Floating system is low-density system that have sufficient buoyancy to float over the gastric contents and remain in the stomach for a prolonged period. While the system floats over the gastric contents, the drug is released slowly at the desired rate, which results in increased gastro-retention time and reduces fluctuation in plasma drug concentration. After floating, this system switched into mucoadhesive based on an interaction between the mucin layer that lines the entire gastric, increasing the intimacy and duration of contact between the dosage form and the biological membrane.

The design of drug formulations is based on the principles of pharmacokinetics, biopharmaceutics and pharmaceutical technology. The framework of the methodology is a step-wise iterative procedure that includes the data on pharmacokinetic and biopharmaceutical properties of the drug itself, the data on the therapeutic range of plasma concentrations, the analytical method for the identification of drug concentrations in artificial and biological fluids, the procedures of mathematical modelling and computer simulation, in vitro and in vivo testing procedures and a clearly defined purpose of the study.

The previous study were obtained the optimum formula of nifedipine tablet which consisted of 12.02% carbopol 934P, 5% gelatin, and 7.98% gas generator. Furthermore, it is important to study the kinetic release of nifedipine, both in vitro and in vivo. The aim of the current study was to develop and evaluate compartmental modelling approach which could explain the pharmacokinetic and biopharmaceutical properties of nifedipine. The proposed model implements one lag compartment which describe the system in a controlled manner.

MATERIALS AND METHODS

Materials

The materials used were nifedipine (Italy), carbopol 934P (Hongkong), citric acid (China), sodium bicarbonate (Germany), polyvinylpyrrolidone K-30 (China), magnesium stearate, Avicel PH 102 (pharmaceutical grade), ethanol 96%, acid hydrochloride (technical grade), and white male rats Wistar strain as subject.

The instruments used were digital and analytical scales, mortar and stamper, sieve no. 18 and 20, dissolution apparatus type II paddle (Electrolab TDT-08L), tablet machine, spectrophotometer UV-Vis mini 1240 (Shimadzu), UPLC (Waters Acquity H Class).

Formulation of floating-mucoadhesive nifedipine tablet

Preparation of tablets was done using 30% drug load of nifedipine in polyvinylpyrrolidone K-30 which described in the previous study⁶. All materials were weighted (Table 1), then nifedipine solid dispersion and citric acid were firstly mixed. On the other side, carbopol 934P and gelatin were blended, then added into the first mixture. Next, the proper amount of sodium bicarbonate and avicel PH 102 were gradually added. Wet granules were sieved no 14 then dried (at a temperature of 50°C for 5 hours). The dried granules were sieved no 16, then magnesium stearate was added. Granules were compressed using tablet machine equipped with a 5.0mm round biconvex punch and die set. After compression, all the tablets were stored in double polythene bags at room temperature for further study.

Table 1. The optimal formula of nifedipine tablet

No	Materials	Amount (mg)
1	Nifedipine solid dispersion	133,3
2	Carbopol 934P	24,04
3	Gelatin	10
4	Citric acid	6,89
5	Sodium bicarbonate	9,07
6	Magnesium stearate	6
7	Avicel PH 102	10,70

Pre-compression parameters

Pre-compression parameters included moisture content and flow property. Moisture content was determined using moisture meter. Flow property was predicted from the rate of 100-gram granules to flow through the funnel freely onto the surface. Free flowing property was obtained when the flow rate of granules is not more than 10 second or more than 10 gram/second.

Post-compression parameters

Hardness and Friability

The hardness and friability of 20 tablets each was determined using the Pfizer hardness tester and Electro lab friabilator test apparatus, respectively⁷.

Content uniformity

Ten tablets were weighed, powdered and equivalent to 50 mg of nifedipine was weighed and dissolved in sufficient quantity of methanol. The solution was suitably diluted with simulated gastric fluid (SGF) pH 1.2±0.05 into 100 mL glass vial and the content of nifedipine was estimated spectrophotometrically at 237 nm using simulated gastric fluid (SGF) pH 1.2 as a blank⁷.

Floating capacity

Floating characteristics of the prepared formulations were determined using simulated gastric fluid (SGF) pH 1.2±0.05, maintained at 37 ±0.5°C. The time between the introduction of the tablet and its buoyancy on the simulated gastric fluid (floating lag time) and the time during which the dosage form remain buoyant (floating duration) were measured⁸.

In vitro mucoadhesive

Fresh rat gastric mucosa was used for in vitro mucoadhesive. The mucosal membrane was cleaned and separated by removing the underlying fat and loose tissues. The mucoadhesive strength of optimal formula was measured on a modified physical balance (Fig. 1). The device was mainly composed of a two-arm balance. The right-arm of the balance was replaced by a small plastic cap vertically suspended through a wire. At the same side, a movable platform was maintained in the bottom order to fix the model mucosal membrane. The fresh gastric mucosa was cut into pieces and washed with simulated gastric fluid (SGF) pH 1.2±0.05. A piece of gastric mucosa was placed to the open mouth of a glass vial, which was placed and tightly fitted in the center of a glass beaker. The simulated gastric fluid (SGF) pH 1.2±0.05 was filled into the glass beaker in such a way that it makes contact with the gastric mucosal surface. Two pans of the balance were balanced with 5 g weight on the left-hand side pan. A weight of 5 g was removed from the left-hand side pan, which lowered the pan along with

the optimal formula over the mucosa. The balance was kept in this position for 5 min contact time, and then slowly the weights were increased on the left-hand side pan till the optimal formula separated from the mucosal surface⁹.



Figure 1. Modified apparatus for mucoadhesion test

In vitro drug release study

Drug release from the tablets was studied using USP dissolution apparatus (Electrolab TDT-042, type II (paddle method)). A tablet was placed inside and immersed in a dissolution vessel (n = 6) containing 900 mL of simulated gastric fluid (SGF) pH 1.2±0.05, maintained at 37 ±0.5°C with a paddle rotation speed 50 rpm. The amount of drug released after 30, 60, 90, 120, 150, 180, 210, 240, 270, 300, 330, and 360 min was determined using UV spectrophotometer (Shimadzu) at 237 nm. Release profiles of the designed formulation were calculated¹⁰.

Drug release kinetics

In vitro release data were subjected to model fitting analysis to know the order of drug release by treating the data according to zero order, first order and Higuchi's release kinetic equations. The zero-order kinetics describes the systems where the drug release rate is independent of time and drug concentration of the dissolved substance. The first-order kinetics describes systems where the drug release rate depends on its concentration. The Higuchi model indicate that the drug release is controlled by the diffusion mechanism. The criterion for selecting the most appropriate model was based on the highest representative regression coefficients (R) value¹¹.

In vivo evaluation

In order to ascertain the pharmacokinetic property and expected clinical efficacy, in vivo evaluation of the optimal formulation containing 30% drug load of nifedipine was carried out. The bioavailability study was conducted using white male rats Wistar strain. Prior ethical approval was taken from the Health Research Ethic Committee, Faculty of Public Health, Diponegoro University, for carrying out this study (Protocol approval number: 216/EC/FKM/2013)^{10,12}.

Drug analysis

Serum samples were analyzed for nifedipine with a validated bioanalytical method using UPLC (Waters Acquity H Class) comprising of a pump (LC-20AD), autosampler (SIL-20AD), the photodiode array detector, and a column oven (CH-30A). The separation was performed on a reverse phase, Waters BEH C18 as stationary phase, and a mobile phase consisting of methanol, acid aqua distillate, acetonitrile with a gradient system (Table 2). Flow rate was 0.3 mL/min, the system was operated at a wavelength of 237 nm, and temperature of the column oven was set at 40°C. Glibenclamide was used as internal standard for analysis of nifedipine¹³.

Table 2. Specification of UPLC

Time (min)	Flow (mL/min)	Methanol (mL)	Acid aqua distillate (mL)	Acetonitrile (mL)
Initial	0,3	50	15	35
1	0,3	45	15	40
3	0,3	35	20	45
3,5	0,3	35	20	45
5	0,3	5	15	80
8	0,3	50	15	35

The peaks of nifedipine and glibenclamide were resolved with good symmetry. The retention time for nifedipine and glibenclamide was 2.59 and 4.23 min, respectively (Fig. 2). The typical assay run time was 8 min. The bioanalytical method was validated as per ICH guidelines. The serum drug concentration-time data was subjected to compartmental analysis using a pharmacokinetic software, WinSAAM to obtain various pharmacokinetic parameters. Relative bioavailability (C_{max} , $T_{1/2}$) was compared to immediate product.

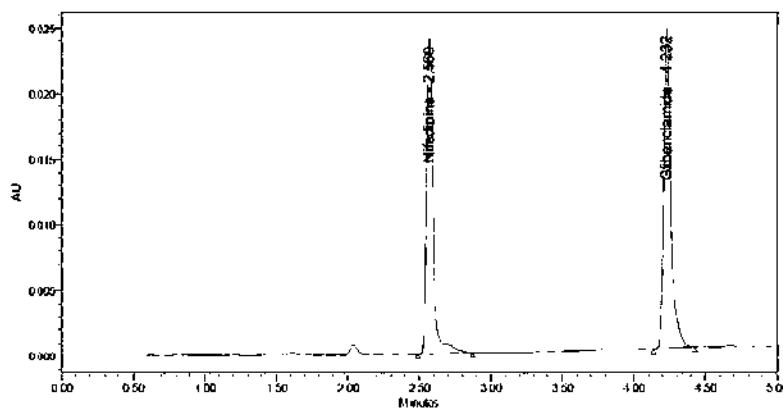
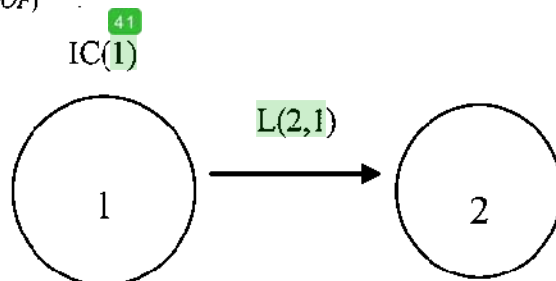

Figure 2. Separation analysis of nifedipine using glibenclamide as internal standard

Modelling analyses

The cumulative amounts of the nifedipine were plotted as a function of time. Data were then analyzed based on the compartmental model approach. In this approach, compartmental models consisted of models with none (model 2) or one (model 3) lag compartment for in vitro drug analysis (Fig. 3) and none (model 3) or one (model 4) lag compartment for in vivo evaluation (Fig. 4). The modelling was performed using WinSAAM. Furthermore, evaluation of model appropriateness to transport data was performed based on the evaluation of visual goodness of fit (GOF)^{14,15}.



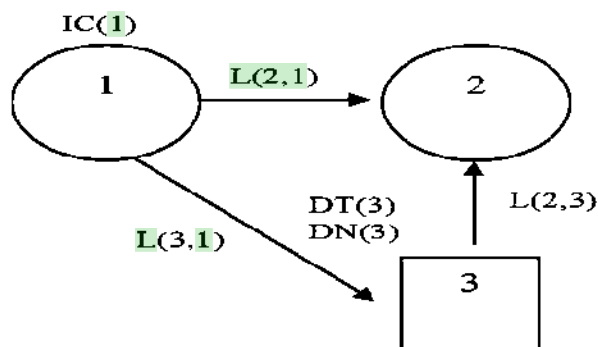

Figure 3. In vitro schematic compartmental models

Notes:

- IC (1) : initial dose amount (in the tablet)
- L (2,1) : coefficient of drug transport from the compartment 1 (tablet) to the compartment 2 (dissolution medium)
- L (3,1) : coefficient of drug transport from the compartment 1 (tablet) to the compartment 3 (lag compartment)
- L (2,3) : coefficient of drug transport from the compartment 3 (lag compartment) to the compartment 2 (dissolution medium)
- DT (3) : delay time of drug in the lag compartment:
- DN (3) : theoretical delay number of partial elements or pseudo-compartment in a certain lag compartment

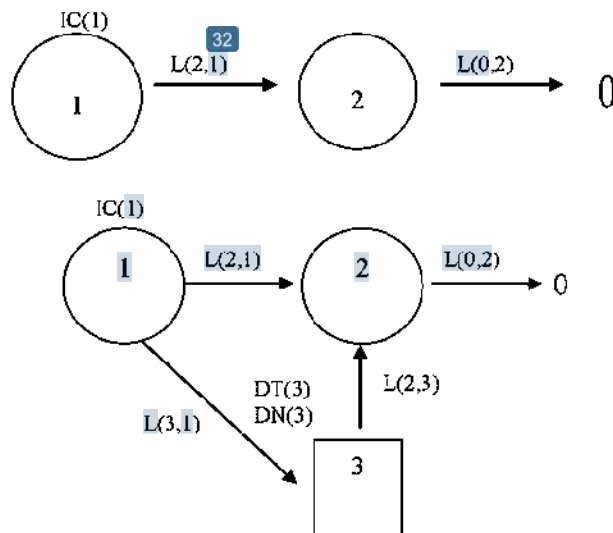

Figure 4. In vivo schematic compartmental models

Notes:

- IC (1) : initial dose amount (in the tablet)
- L (2,1) : coefficient of drug transport from the compartment 1 (tablet) to the compartment 2 (systemic circulation)
- L (0,2) : coefficient of drug transport from the compartment 2 (systemic circulation) to the compartment 0 (elimination)
- L (3,1) : coefficient of drug transport from the compartment 1 (tablet) to the compartment 3 (lag compartment)
- L (2,3) : coefficient of drug transport from the compartment 3 (lag compartment) to the compartment 2 (systemic circulation)
- DT (3) : delay time of drug in the lag compartment:
- DN (3) : theoretical delay number of partial elements or pseudo-compartment in a certain lag compartment

3 RESULT AND DISCUSSION

Physical properties of granules

Physical properties of the granules are shown in Table 3. The results of moisture content has correlated to flow property. The less moisture content gave a good flow properties of the granules.

Evaluation of floating mucoadhesive nifedipine tablet

The weight variation found less than 5%, hardness was within 4-10 kg/cm², friability was less than 1%, and drug content was ranged from 90-110% (Table 3). The weight variation and friability of the optimal formula complied with United State Pharmacopoeia as the tablets were prepared by wet granulation. The data proved that all the physical parameters of optimal formula were within control.

Table 3. Physical properties of optimal formula

Parameters	Optimal formula
Moisture content* (%)	3.00±0.09
Flow rate* (g/sec)	10.68±0.02
Weight variation* (mg)	200.02±0.12
CV (%)	0.06
Hardness* (kg/cm ²)	4.51±0.08
Friability* (%)	0.49±0.01
Content uniformity* (%)	102.17±0.89
CV (%)	0.87
Dissolution profiles C ₃₆₀ * (%)	58.86±0.75
Floating lag time** (second)	100.20±1.82
Total floating duration (hours)	> 24
In vitro mucoadhesive* (N)	0.1011±1.80 ×10 ⁻³

Note:

* Mean ± SD; n = 6

** Mean ± SD; n = 20

Floating capacity

The Floating Lag Time (FLT) and duration of buoyancy was noted visually. The floating lag time was 100.20 second or 1.67 min. The duration of buoyancy time of the optimal formula was found to be 24 hours. The result shows that the optimal formula pass the test as shown in Fig. 5.

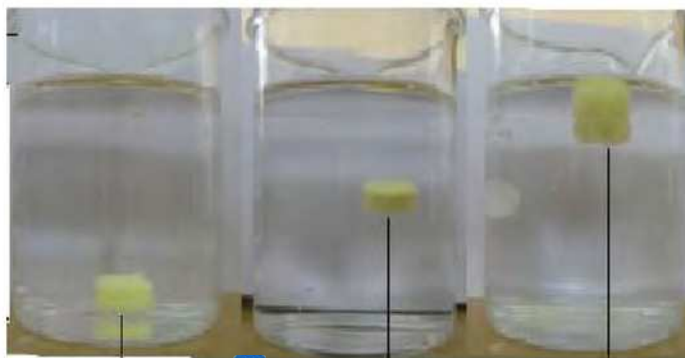

60 Figure 5. Floating lag time and duration of floating

40 The tablet floated immediately upon immersion in to the media and remained floated for 24 hours. Sodium bicarbonate and citric acid were employed as gas forming agents dispersed in the matrix and this formulation was found to be appropriate for achieving desired buoyancy characteristics. Addition of sodium bicarbonate was found essential to ensure rapid

floating. Upon immersion, sodium bicarbonate starts reaction immediately with the acidic dissolution media and added citric acid. This reaction generates sufficient amount of CO₂ which get entrapped and protected within the gel layer formed by hydration of carbopol 934P and gelatin. This leads to decreased density of the tablet, as a result of which the tablet becomes buoyant¹⁰. Buoyancy property is further facilitated by relatively good acid solubility of nifedipin solid dispersion which causes faster penetration of dissolution media into the matrix⁵.

This in turn causes quicker initiation of reaction resulting in faster generation of CO₂ making the tablets more buoyant.

In vitro mucoadhesive

In vitro mucoadhesive is important for mucoadhesion property of tablet. If the mucoadhesive strength is more, then the drug absorption will be more through that site (gastric mucosa) resulting high bioavailability. Mucoadhesive strength may be due to the formation of strong gel from polymer (carbopol 934P and gelatin) which penetrate deeply into the molecules of mucin and show strong bioadhesion, as shown in Table 3.

In vitro drug release study

Release parameters of the tablets are summarized in Fig. 6 and Table 3. Nifedipine release from the prepared tablets was slow, spread over more than 12 hours, and depended on the grade of the controlled release polymer. Accordingly, dissolution requirements for nifedipine sustained release tablets were specified by the USP. The fraction of drug dissolved using USP apparatus type II at 50 rpm is specified for nifedipine sustained release tablets as 10–30% release at 3 hours, 40–65% at 6 hours, and not less than 80% at 12 hours. Optimal formula gave a release profile comparable to the theoretical sustained release administration of nifedipine.

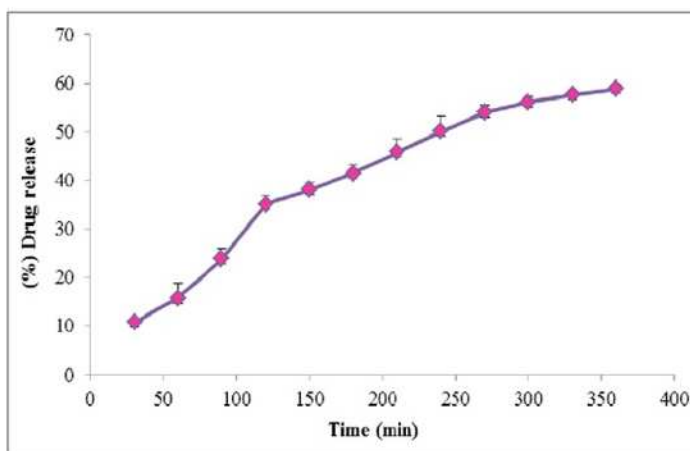

Figure 6. Cumulative drug release (%) vs time (min)

52

Kinetic analysis of dissolution data

The dissolution kinetics of optimal formula were applied to various dissolution models such as zero order, first order, and Higuchi. The best fitted model gives the highest R value (Table 4). Thus, Higuchi model fits best for the dissolution data of optimal formula as it showed the highest value for R which indicate that the drug release from a system in controlled manner. In the dissolution medium, tablet shows swelling and burst release of drug and after that combination of carbopol 934P and gelatin acts as release retardant polymer and gives the release of drug in sustained manner.

Table 4. R values and slope values of floating mucoadhesive nifedipine tablet

Models	R values	Slope values
Zero order	0,9692	11,8345
First order	0,9575	1,9516
Higuchi	0,9916	- 10,3473

Pharmacokinetic evaluation

The in vivo studies in rats revealed that nifedipine formulation exhibited a slow and sustained rate of drug absorption was still detectable in 24 hours. The mean plasma concentration versus time profiles after oral administration was depicted in Fig. 7. The pharmacokinetic parameters, C_{max} and T_{1/2} values were 4.096±0.06 µg/mL and 3.22 hours, respectively. It was found that C_{max} values of optimal formula were higher than immediate formulation using ethyl cellulose and eudragit RL as matrix polymer, which is 1.304±0.12 µg/mL and 1.377±0.21 µg/mL, respectively. This condition causes the prolonged T_{1/2} values when compared with the immediate product.

2

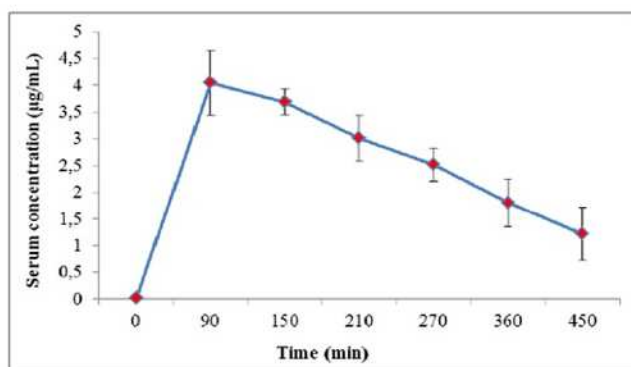

Figure 7. Overlay mean serum nifedipine concentration time profiles after oral single dose administration of optimal formulation

Modelling of nifedipine transport

The results of the compartmental model were presented in Fig. 8 (presentation of in vitro model fitting) and Fig. 9 (presentation of in vivo model fitting). Model evaluation based on the standard goodness of fit evaluation, i.e. the correlation of QO (observed transport of nifedipine) versus QC (predicted transport of nifedipine) presented together with line of identity¹⁵. Data in Fig. 8 showed model B (in vitro evaluation) and Fig. 9 showed model B (in vivo evaluation) could describe the observation data better than other model. Such indication was in agreement with data on Fig. 10, where the goodness of fit evaluations also indicated the less deviation between model prediction and the observed data.

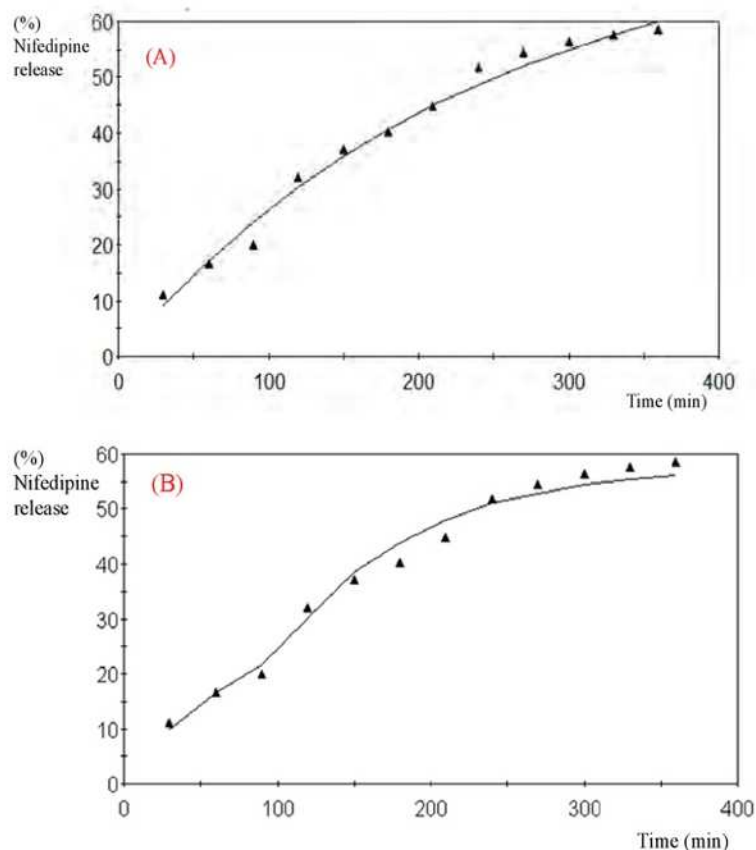

Figure 8. Curve fitting of nifedipine in the dissolution medium: two compartment (A); three compartment (B)

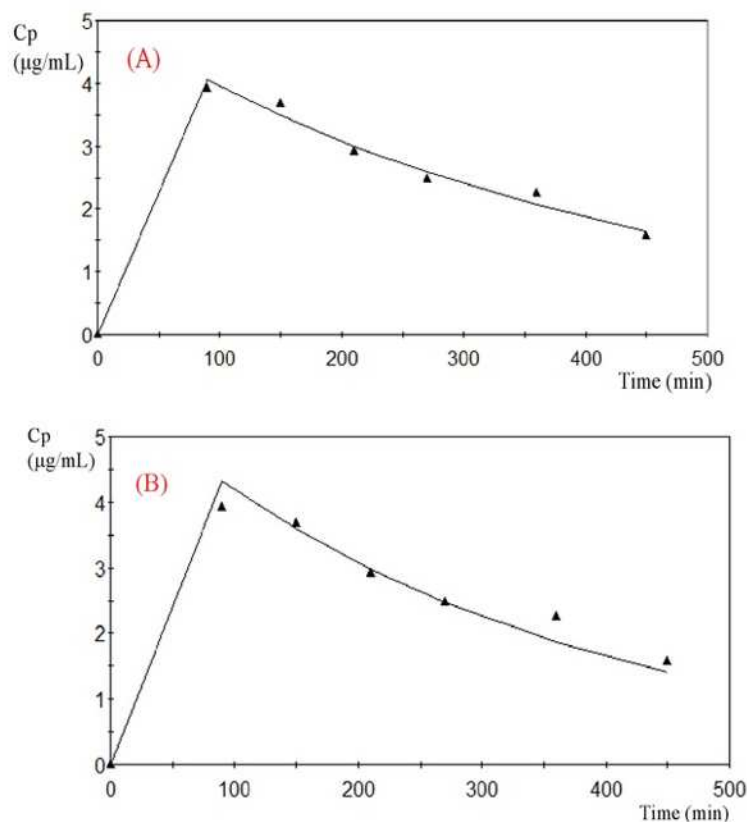
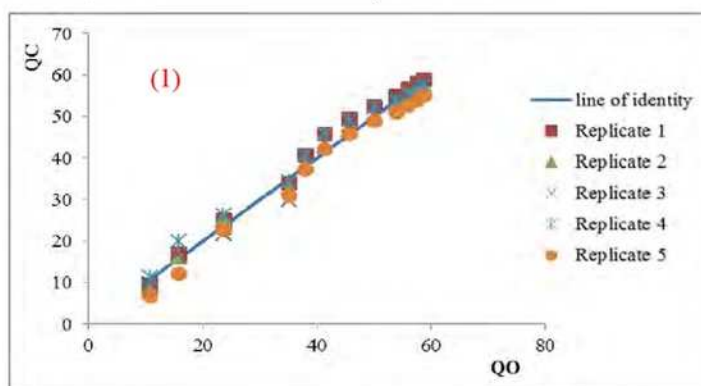

Figure 9. Curve fitting of nifedipine serum concentration: three compartment (A); four compartment (B)

The nifedipine transport was best described using model B-B. As presented in Fig. 8 and 9, the model implements 3 compartments with separate lag compartment. The presence of lag compartment may retain drug molecules longer before entering into the acceptor compartment (compartment 2). The lag compartment acts a barrier for drug to release, both in dissolution media and systemic circulation.



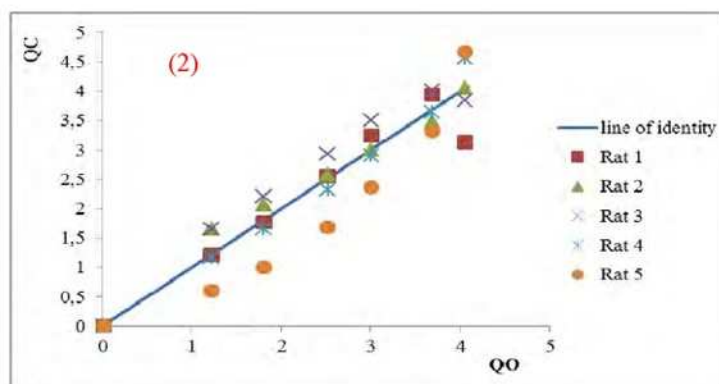

Figure 10. Typical examples of goodness of fit (GOF) of nifedipine fitted using model 1 (in vitro) and model 2 (in vivo). Panels depict GOF based on the correlation of QO (observed transport of nifedipine) versus QC (predicted transport of nifedipine) presented together with line of identity (solid line)

CONCLUSION

The compartmental modelling approach of floating mucoadhesive nifedipine tablet was successfully carried out. Satisfactory correlation were also observed between the in vitro dissolution and in vivo absorption. The lag compartment was formed from polymers, i.e carbopol 934P and gelatin. This polymers play major role in controlling the drug release from tablet, thus achieving the desired bioavailability.

ACKNOWLEDGEMENTS

The authors thank to Technology Pharmacy Research Laboratory and Pharmacology Research Laboratory, Yayasan Pharmasi College of Pharmacy, Semarang, Indonesia for providing all the facilities to carry out this work.

REFERENCES

- [1] Moffat, C. 24. J. Selton, MD, Widdop, W: Clarke's Analysis of Drugs and Poisons, Pharmaceutical Press 2005.
- [2] Amit JK, Rammulrajshih R, 50. Jali D, Kinal P and Pradeep A: Hydrodynamically Balanced Systems (HBS): Innovative Approach of Gastroretention: A Review. International Journal of PharmTech Research 2011; 3 (3): 1495-1508.
- [3] Borase, CB: Floating Systems for Oral Controlled Release Drug Delivery. International Journal of Applied Pharmaceutics 2012; 4 (2): 1-13.
- [4] Grabnara I, Belici A, Mrhara A, Karba R: The role of Pharmacokinetic Modelling and Computer Simulation in Drug Formulation Design. Computers in Biology and Medicine 1998; 28: 365-376.
- [5] Ikasari ED, Fudholi A, Martono S, and Marchab 36. A Formula Optimization of Nifedipine Tablet Combination with Floating Mucoadhesive System in a Simple Lattice Design. International Journal of Pharmaceutical Sciences and Research 2015; 6 (5): 1837-1844.
- [6] Ikasari ED, Fudholi A, Martono S, and Marchaban: Investigation of Nifedipine Solid Dispersion with Solvent PVP K-30. International Journal of Pharmacy and Pharmaceut 13. Sciences 2015; 7 (4): 389-392.
- [7] Rao, VS, Golla A, and Padmalatha: Formulation and Evaluation of Gastroretentive Floating Tablets of Nifedipine. World Journal of Pharmacy and Pharmaceutical Sciences 2014; 3 (12) 975-983.
- [8] Nmlady M, Attallah K, Sayed M, and Gouda A: Formulation and Evaluation of a Buoyant Ranitidine Hydrochloride System. International Journal of Pharmaceutical Sciences Review and Research 2014; 24 (2): 4-8.
- [9] Patel B, Patel P, Bhosale A, Hardikar S, Mutha S, and Chaulang G: Evaluation of Tamarind Seed Polysaccharide (TSP) as a Mucoadhesive and Sustained Release Component of Nifedipine Buccoadhesive Tablet & Comparison with HPMC and Na CMC. International Journal of PharmTech Research 2009; 1 (3): 403-410.
- [10] Shakya R, Thapa P, Saha, RN: In Vitro and In Vivo Evaluation of Gastroretentive Floating Drug Delivery System of Ofloxacin. Asian Journal of Pharmaceutical Sciences 2013; 8: 191-198.
- [11] Chatap VK, Patil PL, Patil SD: In-Vitro, Ex-Vivo Characterization of Furosemide Bounded Pharmacosomes for Improvement of Solubility and Permeability. Advances 21. Pharmacology and Pharmacy 2014; 2 (5): 67-76.
- [12] Cheng C, Wue PC, Lee HY, Hsu KY: Development and Validation of an In vitro-In vivo Correlation (IVIVC) Model for Propranolol Hydrochloride Extended-release Matrix Formulations. Journal of Food and Drug Analysis 2013; XXX: 1-7.
- [13] Guo Y, Dai J, Ojan G, Guo N, Maa Z, Guo XJ: Determination of Nifedipine in Human Plasma and Its Use in Bioequivalence Study. International 22. Journal of Pharmaceutics 2007; 341: 91- 96.
- [14] Godfrey KR, Arundel P.A, Dong Z, Bryant R: Modelling the Double Peak Phenomenon in Pharmacokinetics. Computer Methods and Programs in Biomedicine 2011; 104: 62-69.
- [15] Nugroho AK, Binnarjo A, Hakim AR, Ermawati, Y: Compartmental Modelling Approach of Losartan Transdermal Transport In Vitro. Indonesian Journal of Pharmacy 2014; 25 (1): 31-38.
- [16] Lokhandwala H, Deshpande A, and Deshpande S: Kinetic Modelling and Dissolution Profiles Comparison: An Overview. International Journal of Pharma and Bio Sciences 2013; 4 (1): 728-737.
- [17] Nokhodchi A, Raja S, Patel P, and Addo KA: The Role of Oral Controlled Release Matrix Tablets in Drug Delivery Systems. BioImpacts 2012; 2 (4): 175-187.
- [18] Mallick S, Gupta BK, and Ghosal SK: Assesment of Bioavailability of Experimental Controlled Release Microcapsule of Nifedipine. Biopharmacy 2000; 57 (3): 175-180.

Publikasi 5

ORIGINALITY REPORT

41 %

SIMILARITY INDEX

35 %

INTERNET SOURCES

30 %

PUBLICATIONS

19 %

STUDENT PAPERS

PRIMARY SOURCES

1	www.i-scholar.in Internet Source	4 %
2	Submitted to Petroleum Research & Development Center Student Paper	4 %
3	www.ijppsjournal.com Internet Source	4 %
4	ijrpc.com Internet Source	2 %
5	msc.fe.uni-lj.si Internet Source	2 %
6	jddtonline.info Internet Source	1 %
7	www.hrpub.org Internet Source	1 %
8	ijpdt.com Internet Source	1 %
9	globalresearchonline.net	

10

V. M. Patel. "Physicochemical Characterization and Evaluation of Buccal Adhesive Patches Containing Propranolol Hydrochloride", *Current Drug Delivery*, 07/01/2006

Publication

1%

11

www.ijrapronline.com

Internet Source

1%

12

Submitted to Jawaharlal Nehru Technological University

Student Paper

1%

13

Submitted to International Medical University

Student Paper

1%

14

Pal, Dilipkumar, and Amit Kumar Nayak. "Novel tamarind seed polysaccharide-alginate mucoadhesive microspheres for oral gliclazide delivery: in vitro–in vivo evaluation", *Drug Delivery*, 2012.

Publication

1%

15

J BYERS. "Pharmacokinetic Modeling", *Pharmacology*, 2009

Publication

1%

16

file.scirp.org

Internet Source

1%

17

Submitted to Manipal University

Student Paper

1%

18

Kallem, Raja Reddy, Jaswanth Kumar Inamadugu, Mullangi Ramesh, and J. V. L. N. Seshagirirao. "Sensitive LC-MS/MS-ESI method for simultaneous determination of nifedipine and atenolol in human plasma and its application to a human pharmacokinetic study : LC-MS/MS quantification of nifedipine and atenolol in human plasma", Biomedical Chromatography, 2013.

Publication

1%

19

pharmacologyonline.silae.it

Internet Source

1%

20

Submitted to AIMST University

Student Paper

1%

21

doaj.org

Internet Source

1%

22

Sharma, A., S. Jaiswal, M. Shukla, M. Sharma, P. M. S. Chauhan, N. Rangaraj, K. Vaghasiya, and J. Lal. "HPLC-MS-MS Method Development and Validation of Antileishmanial Agent, S010-0269, in Hamster Serum", Journal of Chromatographic Science, 2015.

Publication

1%

openaccess.leidenuniv.nl

23

Internet Source

<1%

24

Laís Nohemann, Marina Penteado de Almeida, Priscileila Colerato Ferrari. "Floating ability and drug release evaluation of gastroretentive microparticles system containing metronidazole obtained by spray drying", Brazilian Journal of Pharmaceutical Sciences, 2017

Publication

<1%

25

scientific-journals.co.uk

Internet Source

<1%

26

gnu.inflibnet.ac.in

Internet Source

<1%

27

www.ijaponline.org

Internet Source

<1%

28

home.izum.si

Internet Source

<1%

29

www.ijrpbsonline.com

Internet Source

<1%

30

Kok-Khiang Peh. "In Vivo Performance of a Multiparticulate Matrix, Controlled-Release Theophylline Preparation", Drug Development and Industrial Pharmacy, 4/1/1996

Publication

<1%

31	Submitted to Eastern Mediterranean University Student Paper	<1%
32	www.freepatentsonline.com Internet Source	<1%
33	Submitted to CSU, San Jose State University Student Paper	<1%
34	Akhter, Dewan T.; Uddin, Riaz; Huda, Naz H. and Sutradhar, Kumar B.. "DESIGN AND FORMULATION OF TWICE DAILY NIFEDIPINE SUSTAINED RELEASE TABLET USING METHOCEL K15M CR AND METHOCEL K100LV CR", International Journal of Pharmacy & Pharmaceutical Sciences, 2012. Publication	<1%
35	mdpi.com Internet Source	<1%
36	fa.itb.ac.id Internet Source	<1%
37	pubmedcentralcanada.ca Internet Source	<1%
38	Submitted to Yeungnam University Student Paper	<1%
39	P. Kumar. "Gastroretentive Drug Delivery System of Ranitidine Hydrochloride Based on Osmotic Technology: Development and	<1%

Evaluation", Current Drug Delivery, 10/01/2008

Publication

-
- | | | |
|----|------------------------------------------------------------------------------------------------------------------------------------------------------------------------------------------------------------------|-----|
| 40 | www.scribd.com
Internet Source | <1% |
| 41 | cosmo.nyu.edu
Internet Source | <1% |
| 42 | jpsbr.org
Internet Source | <1% |
| 43 | www.irjpas.com
Internet Source | <1% |
| 44 | www.ijpr-online.com
Internet Source | <1% |
| 45 | innovareacademics.in
Internet Source | <1% |
| 46 | www.accessdata.fda.gov
Internet Source | <1% |
| 47 | Kok-Khiang Peh. "In Vivo Bioavailability of a Multiparticulate Matrix Sustained-Release Theophylline Preparation Under Fed and Fasted Conditions", Drug Development and Industrial Pharmacy, 1997
Publication | <1% |
| 48 | CHAUDHARI, SHILPA P.; KAMBLE, SHRENIK C. and SALVANKAR, SHAIENDRA S..
"DESIGN & IN-VITRO EVALUATION OF | <1% |

GASTRORETENTIVE, SUSTAINED RELEASE
TABLET FORMULATION OF ACYCLOVIR
USING HYDROPHILIC POLYMERS",
International Journal of Pharmacy &
Pharmaceutical Sciences, 2013.

Publication

49

www.sysrevpharm.org

Internet Source

<1%

50

ijddr.in

Internet Source

<1%

51

Preeti Subhedar. "Effect of Polymer Concentration on Sustained Release Microparticles of Metformin Hydrochloride Prepared by Using Spray Dryer", Polymer-Plastics Technology and Engineering, 01/2010

Publication

<1%

52

www.ijddr.in

Internet Source

<1%

53

www.ajol.info

Internet Source

<1%

54

Averineni, Ranjith Kumar, Subramanian Ganesa Sunderajan, Srinivas Mutalik, Usha Nayak, Gopal Shavi, Karthik Armugam, Sreenivasa Reddy Meka, Sureshwar Pandey, and Udupa Nayanabhirama. "Development of mucoadhesive buccal films for the treatment of

<1%

oral sub-mucous fibrosis: a preliminary study",
Pharmaceutical Development and Technology,
2009.

Publication

55

Jagdale, Swati C. Pawar, Chandrakala R..
"Application of design of experiment for polyox
and xanthan gum coated floating pulsatile
delivery of", BioMed Research International,
Annual 2014 Issue

<1%

Publication

56

ijpsnonline.com

Internet Source

<1%

57

www.authorstream.com

Internet Source

<1%

58

Vummaneni, Vishnumurthy; Nagpal, Dheeraj
and Surapaneni, Srikar. "Formulation and
optimization of famotidine floating tablets
using 2³ factorial design", Journal of Pharmacy
Research, 2012.

<1%

Publication

59

Ahmed, Abdul B. and Nath, Lila K.. "Fabrication
and in vitro evaluation of floating matrix tablet
of nicorandil using factorial design", Journal of
Pharmacy Research, 2011.

<1%

Publication

60

Tarkase, K. N.; Tarkase, M. K.; Dokhe, M. D.

<1%

and Wagh, V. S.. "FORMULATION, OPTIMIZATION AND COMPARATIVE EVALUATION OF GASTRORETENTIVE DRUG DELIVERY SYSTEM OF CINNARIZINE AND DOMPERIDONE MALEATE FLOATING TABLET", International Journal of Pharmaceutical Sciences Review & Research, 2012.

Publication

61

Luppi, B., F. Bigucci, T. Cerchiara, V. Andrisano, V. Pucci, R. Mandrioli, and V. Zecchi. "Micelles Based on Polyvinyl Alcohol Substituted with Oleic Acid for Targeting of Lipophilic Drugs", Drug Delivery, 2004.

<1%

Publication

Exclude quotes Off

Exclude matches Off

Exclude bibliography Off